



DAS HERZ DER FRISCHE

WATER COOLED

# SHELL AND TUBE CONDENSERS

DP-200-6 EN

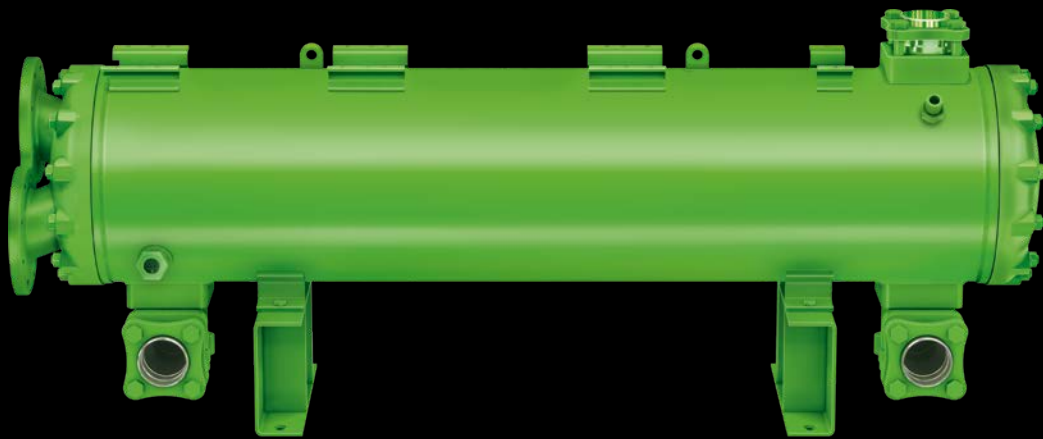

## NEW MODELS



HFO  
READY



PROPANE



MARINE



## Water cooled shell and tube condensers and discharge gas desuperheaters

### Two related product series, many applications

The water cooled shell and tube condensers from BITZER have been a standard in refrigeration and air conditioning technology for years due to their well-known reliability and performance. The K series consists of two designs and thus meets the requirements of a wide variety of applications. The unique brazing process between tubes and tube sheets ensures excellent vibration stability and high safety in terms of tightness.

### New models

The new models K6703.(B) and K8503.(B) in standard and seawater design extend the condenser capacity to the range above 1000 kW.

### Standard design for normal water

The heat exchanger tubes are characterised by high material thickness; the tube sheets are plastic-coated. This series is suitable for all types of coolants that do not attack copper.

### Seawater resistant design

The K..B models are proven over decades in all maritime applications. They are extremely corrosion-resistant to seawater. The low-fouling profile tubes and the plastic coating of tube sheets and coolant reversing covers make them the first choice. On models up to K813HB, liquid refrigerant is drained through an dip tube and, from K1053HB on, through two refrigerant outlets.

### Discharge gas desuperheaters

Construction sizes K1053H to K4803T are also available in the standard design for normal water as discharge gas desuperheaters. All that is required is to order the optional second refrigerant outlet.



Contents	Page
<b>Construction features</b>	3
<b>Performance Data/Technical Data</b>	4
<b>Maximum allowable pressure</b>	5
<b>Approvals</b>	5
<b>Effect of the fouling factor</b>	5
<b>BITZER SOFTWARE</b>	5
<b>For all common refrigerants and coolants</b>	6
<b>New refrigerants with low global warming potential</b>	6
<b>Customised versions</b>	7
<b>Discharge gas desuperheaters</b>	7
<b>Standard design</b>	
Dimensional drawings	8
Dimensions	9
<b>Seawater resistant design</b>	
Dimensional drawings	10
Dimensions	11
<b>Coolant reversing covers</b>	12
<b>Refrigerant and coolant connections</b>	13
<b>Fixing rails</b>	14
<b>Fixing plates</b>	15

### Explanation of model designation

Example

**K** 1053 H B – 4

K = Shell and tube condenser

K **1053** H B – 4

Code

K 1053 **H** B – 4

Fixing brackets

N = bottom

H = bottom and top for single compressor assembly (semi-hermetic)

T = bottom and top for single and tandem compressor assembly

K 1053 H **B** – 4

Seawater resistant design

K 1053 H B – **4**

Number of coolant passes

## Construction features

// For all common refrigerants and coolants

### Refrigerant side

// Finned high performance tubes

// Refrigerant connections: pipe thread or flange

- inlet:
  - up to K813H(B) Rotalock adaptor
  - from K1053H(B) brazing bush with flange
- outlet: Shut-off valve
- various adaptor and valve combinations optional
- Discharge gas desuperheater special version:
  - Connection for second refrigerant outlet from K1053H to K4803T

// Connection for pressure relief valve:

- internal thread: 3/8-18 NPTF
- external thread 1 1/4-12 UNF
- various adaptors optional

// Sight glass with reflective grooves as standard

### Coolant side

// Tubes with low-fouling profile inside

// Coolant connections: pipe thread or flange

// Coolant drain from K573H(B)

// Additional vent plug from K3803T(B)

### Protective charge

// 0,2 .. 0,5 bar nitrogen

### Strong construction for easy maintenance

- // High safety in terms of tightness:
  - Heat exchanger tubes are brazed into tube sheets.
- // Easy to clean:
  - Both coolant reversing covers can be removed.
- // Flexible:
  - Coolant reversing covers of connection and reversing end are exchangeable.
- // Fixing brackets
  - fixing brackets at the bottom for stable installation
  - models H and T: additional fixing brackets on top for space-saving compressor installation
  - fitting fixing plates and fixing rails optionally available

### Materials

// Heat exchanger tubes

- standard design: Copper (ISO code Cu-DHP; UNS code C12200)
- seawater resistant design: copper-nickel 90/10 (ISO code CuNi10Fe1Mn; UNS code C70600)

// Shells: carbon steel P265GH

// Tube sheets: carbon steel P265GH, plastic-coated

// Coolant reversing covers: cast iron EN-GJL-250 or carbon steel P265GH, plastic-coated in the seawater resistant design

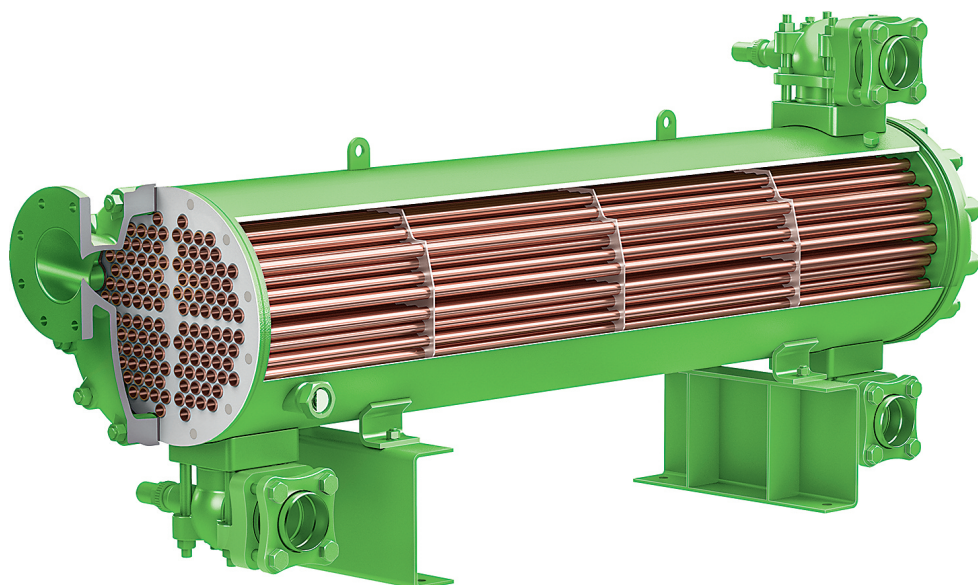



## Performance Data/Technical Data

Model	Performance data for 2-pass design					Vessel volume		Maximum refrigerant charge <sup>③</sup>			Weight kg
	Condenser capacity <sup>①</sup>	Nominal coolant flow rate	Pressure drop	Maximum coolant flow <sup>②</sup>	Minimum coolant flow	Refrigerant side	Coolant side	R448A R449A	R404A	R290	
	kW	m <sup>3</sup> /h	kPa	m <sup>3</sup> /h	m <sup>3</sup> /h	dm <sup>3</sup>	dm <sup>3</sup>	kg	kg	kg	
<b>Standard design</b>											
<b>K033.</b>	4.0	0.58	2	1.38	0.43	3.8	0.4	3.8	3.6	1.7	10
<b>K073H</b>	7.3	1.08	2	2.75	0.85	3.4	0.7	3.4	3.3	1.5	11
<b>K123H</b>	14.8	2.14	10	2.75	0.85	5.1	0.9	5.1	4.9	2.3	14
<b>K203H</b>	20.6	2.97	8	6.42	1.28	11.8	1.8	11.9	11.3	5.3	25
<b>K283H</b>	30.3	4.37	10	8.56	1.71	11.3	2.1	11.4	10.9	5.1	27
<b>K373H</b>	52.3	7.55	23	10.71	2.14	14.5	3.1	14.6	13.9	6.5	35
<b>K573H</b>	72.0	10.39	12	17.83	3.57	29.4	5.8	29.7	28.3	13.2	59
<b>K813H</b>	91.7	13.23	12	22.7	4.54	27.7	7.0	27.9	26.6	12.5	62
<b>K1053H</b>	146.7	21.2	36	22.7	4.54	40.0	9.3	40.4	38.4	18.0	85
<b>K1353T</b>	187.8	27.1	36	29.2	5.84	37.0	11.5	37.3	35.6	16.7	9
<b>K1973T</b>	269	38.9	35	42.2	8.43	76.0	18.8	76.7	73.0	34.2	195
<b>K2923T</b>	387	55.9	34	61.5	12.65	67.0	25.0	67.6	64.3	30.2	230
<b>K3803T</b>	511	73.7	34	81.1	16.23	108.0	37.4	109.0	103.7	48.6	335
<b>K4803T</b>	657	94.9	35	103.9	20.8	98.0	45.0	98.9	94.1	44.1	360
<b>K6703.</b>	811	117	26	146	29.0	201	74.2	202.8	193.0	90.5	600
<b>K8503.</b>	1025	148	26	185	37.0	181	88.1	182.6	173.8	81.5	650
<b>Seawater resistant design</b>											
<b>K033.B</b>	3.9	1.20	9	1.38	0.43	3.8	0.4	3.8	3.6	1.7	11
<b>K073HB</b>	7.8	2.60	11	2.75	0.85	3.4	0.7	3.4	3.3	1.5	12
<b>K123HB</b>	11.1	2.60	14	2.75	0.85	5.1	0.9	5.1	4.9	2.3	18
<b>K203HB</b>	16.7	4.63	20	5.14	1.28	11.8	1.8	11.9	11.3	5.3	29
<b>K283HB</b>	23.3	6.15	19	6.85	1.71	11.3	2.1	11.4	10.9	5.1	30
<b>K373HB</b>	36.0	7.70	24	8.55	2.14	14.5	3.1	14.6	13.9	6.5	38
<b>K573HB</b>	58.2	13.16	18	14.65	3.57	29.4	5.8	29.7	28.3	13.2	66
<b>K813HB</b>	74.4	16.82	18	18.70	4.54	27.7	7.0	27.9	26.6	12.5	68
<b>K1053HB</b>	98.5	16.82	24	18.70	4.54	40.0	9.3	40.4	38.4	18.0	94
<b>K1353TB</b>	125.9	21.6	23	23.95	5.84	37.0	11.5	37.3	35.6	16.7	98
<b>K1973TB</b>	182	31.2	24	34.6	8.43	76.0	18.8	76.7	73.0	34.2	200
<b>K2923TB</b>	263	45.5	23	50.6	12.65	67.0	25.0	67.6	64.3	30.2	235
<b>K3803TB</b>	347	59.9	23	66.7	16.23	108.0	37.4	109.0	103.7	48.6	340
<b>K4803TB</b>	444	76.8	23	85.4	20.8	98.0	45.0	98.9	94.1	44.1	365
<b>K6703.B</b>	591	108	23	120	29.0	201	74.4	202.4	193.0	90.5	620
<b>K8503.B</b>	751	137	23	152	37.0	181	91.3	182.6	173.8	81.5	670

① The performance data are based on:

Refrigerant: R134a

2-pass cooling

Refrigerant inlet temperature: 90°C

Fouling factor on the refrigerant side: 0.00004 m<sup>2</sup>K/W

### Standard design

Condensing temperature: 40°C

Coolant inlet temperature: 29°C

### Seawater resistant design

Condensing temperature: 35°C

Coolant inlet temperature: 25°C

The condenser capacity is strongly influenced by system operating conditions.

For performance data for other refrigerants and coolant, see BITZER SOFTWARE.

② These specifications take into account a maximum flow velocity of 2.0 m/s for the seawater resistant design.

This is necessary for this design to protect the tube profile from wear.

③ At 20°C liquid temperature and 90% vessel volume

Individual performance data see BITZER SOFTWARE.

## Maximum allowable pressure

- // Refrigerant side: 33 bar / -10 to 120°C
- // Coolant side: 10 bar / -10 to 95°C
- Temperatures below 4°C only with anti-freeze agent

These data apply to CE approval in accordance with the EU Pressure Equipment Directive. They may deviate depending on the approval scheme.

## Approvals

### Stationary applications

- // CE: EU Pressure Equipment Directive 2014/68/EU
- // EAC with Declaration of Conformity
- // SELO – China Manufacturing License

### Marine applications

- // Bureau Veritas  
(BV Rules for the Classification of Steel Ships)
- // DNV-GL  
(GL Rules – Ship Technology – Seagoing Ships)
- // Russian Maritime Register of Shipping (RS Rules for the Classification and Construction of Sea-going Ships)

## Influence of the fouling factor

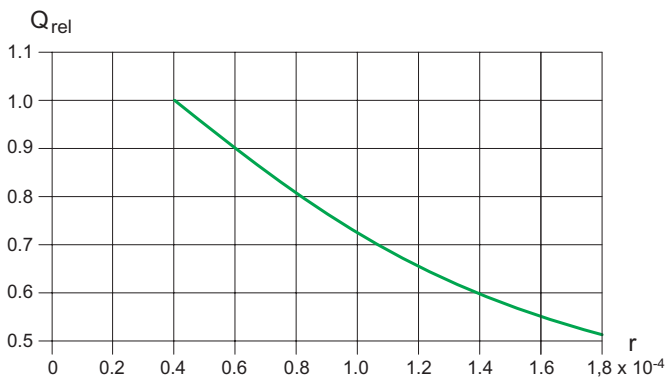

The calculation of condenser performance in the BITZER SOFTWARE does include a fouling factor. The default value is representing clean fresh water. For seawater cooling, please select an appropriate fouling factor or alternatively select the condenser with 10% to 20% spare capacity.



The BITZER SOFTWARE is available in many languages as a download for Windows as well as a web-based version. It is compatible with any browser and is always up to date. The program is also suitable for tablets and smartphones.

The BITZER SOFTWARE covers:

- // Performance data for all common refrigerants under freely selectable operating conditions
- // All relevant technical data
- // Calculation results and individually designed performance tables for condensers
- // Accessories for the design of compound systems
- // All relevant technical documents
- // More BITZER products

[bitzer-software.com](http://bitzer-software.com)

**BITZER Software v6.9.0 rev2049**

Start page // Calculation // Options // Extra // Homepage

Water-cooled Condensers

Series: Standard

Refrigerant: R134a

Cooling agent: Water

Concentration in water: 0

Condenser selection

Condenser capacity: 100

Condenser type: K3803T

Passes no.: 4

Operating point

Condensing temperature: 40 °C

Water inlet temp.: 35 °C

Volume flow: 10 m<sup>3</sup>/h

Operating conditions

Subc. (in condenser): 1 K

Fouling factor: 0.00004 m<sup>2</sup>/KW

20/09/2018 09:52:55

Result Limits Technical Data Dimensions Information Documentation

Water speed < 1.0 m/s (Influence of fouling).

Estimated calculation

Parameter	Value
Condenser type	K3803T
Passes no.	4
Condenser Capacity	54.2 kW
Allowed max. capacity	563 kW
Condensing SDT	40.0 °C
Water outlet temp.	39.7 °C
Volume flow	10.00 m <sup>3</sup> /h
Vol. flow min.	8.11 m <sup>3</sup> /h
Vol. flow max.	40.6 m <sup>3</sup> /h
Fluid velocity	0.62 m/s
Pressure drop	0.04 bar



## For all common refrigerants and coolants

### Permitted refrigerants

// R134a  
// R22  
// R290, R1270  
// R1234yf  
// R1234ze(E)  
// R404A  
// R507A  
// R407C  
// R448A  
// R449A  
// R450A  
// R513A

Other refrigerants and refrigerant blends with temperature glide >2 K upon request.

### Permitted coolants

// Industrial water  
// Fresh water  
// Process water  
// Seawater  
// Ethylene glycol/water  
// Propylene glycol/water  
// CaCl<sub>2</sub> in water  
// Tyxofit 1.15 in water

As a service, BITZER checks the suitability of the tube materials on presentation of a water analysis. The basis for the check is the current state of experience. However, due to the complex conditions, an absolute warranty of corrosion resistance cannot be given.

For corrosive coolants, select the seawater resistant design.

Overdosing the anti-freeze agent can lead to increased pressure drops and poorer heat transfer properties.

 HFO  
READY

 HFO BLEND  
READY

 R290  
PROPANE

## New refrigerants with low warming potential

All shell and tube condensers can be used with new low greenhouse warming potential (GWP) refrigerants. These refrigerants are important tools to reach the emission reductions of the EU Regulation 517/2014 and similar scenarios clearly decided worldwide. Their use is in line with our innovation targets.

The unsaturated fluorinated hydrocarbons (HFO) R1234yf and R1234ze(E), two variants of tetrafluoropropene, play a central role in this. They can be used as pure substances or as components of blends.

The pure substances R1234yf and R1234ze(E) are classified as flammable in A2L according to ISO817. All shell and tube condensers can be used with the environmentally friendly refrigerants R290 propane and R1270 propene.

For flammable refrigerants, the risk assessment for the system has to be made reflecting the flammability and it must be constructed in accordance with national or local regulations. If the risk assessment classifies for the installation area as an explosion protection zone, the shell and tube condensers can not be used. Consultation with BITZER is absolutely necessary.

Further information on these refrigerants can be found in Refrigerant Report A-501.

## Customised versions

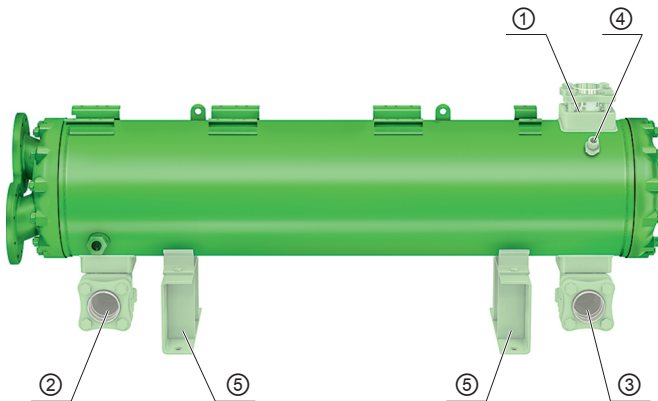

Individual components of each shell and tube condenser can be delivered in customised positions if necessary.

- ① Refrigerant inlet
- ② Refrigerant outlet
- ③ Additional refrigerant outlet according to model
- ④ Connection for the pressure relief valve
- ⑤ Lower fixing brackets

## Matching accessories

- // Fixing plates for compressors
- // Fixing rails
- // Adaptor for connecting the pressure relief valve

## Discharge gas desuperheaters

Discharge gas desuperheaters increase system efficiency. They lower the temperature of the refrigerant discharged by the compressor, as shown in the figure from A to B.

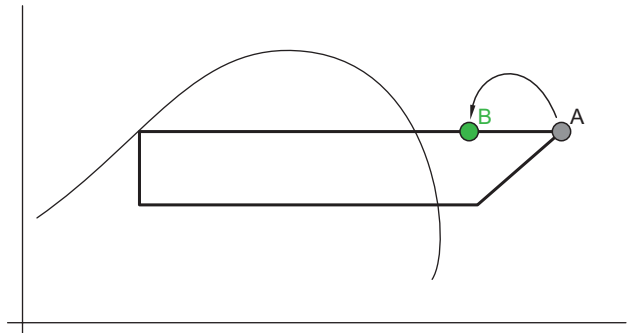

The amount of heat extracted can be used advantageously in a heat recovery system, since it is present at a higher temperature.

Discharge gas desuperheaters are always useful if the discharge gas is too hot for the entire process. A discharge gas desuperheater reduces the discharge gas temperature.

In 2-stage refrigeration systems, for example, this makes sense if the discharge gas in the low temperature stage is too hot to be efficiently compressed further directly in the medium temperature stage.

Discharge gas desuperheaters increase the efficiency of the medium temperature stage and at the same time ensure sufficient motor cooling.

All BITZER shell and tube condensers with a second refrigerant outlet downwards: K123HB .. K8503TB and the special versions with 2nd refrigerant outlet of K1053H .. K4803T can be used as discharge gas desuperheater.

## Additional refrigerant outlet

Model	K033NB K073HB	K123HB K203HB K283HB	K373HB K573HB K813HB K1053H* K1053HB K1353T* K1353TB	K1973T* K1973TB	K2923T* K2923TB	K3803T* K3803TB K4803T* K4803TB	K6703TB K8503TB
Additional refrigerant outlet	–	1 <sup>1</sup> / <sub>4</sub> -12 UNF	1 <sup>3</sup> / <sub>4</sub> -12 UNF	2 <sup>1</sup> / <sub>4</sub> -12 UNF	DN50	DN80	DN80

The additional refrigerant outlet is equipped with a sealing nut or blind flange. Valve available as accessory – see Price List.

\* Special design

Standard design

Dimensional drawings

K033N  
K033H  
K073H  
K123H

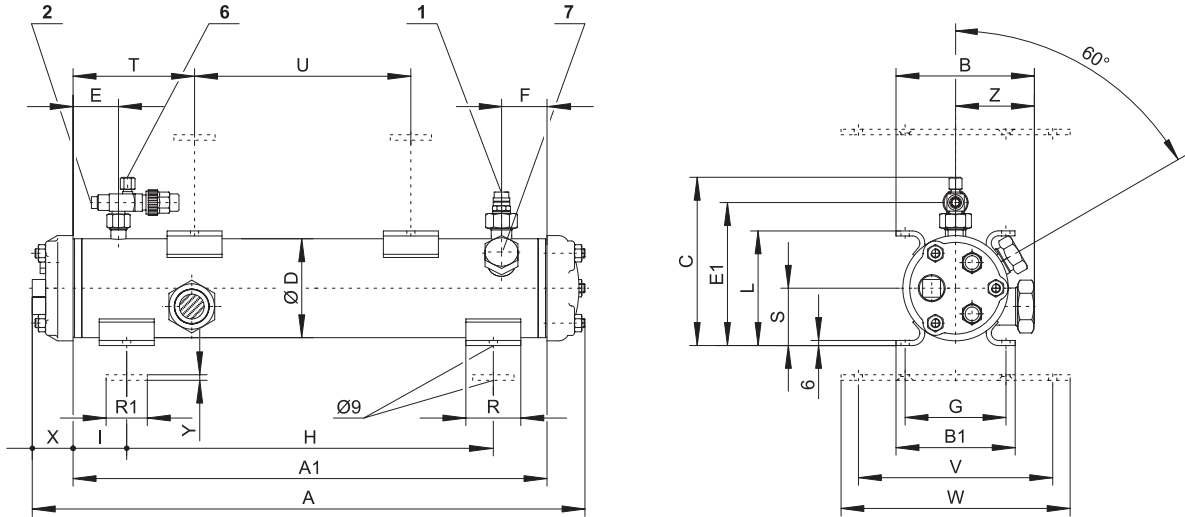

K203H  
K283H  
K373H  
K573H  
K813H  
K1053H

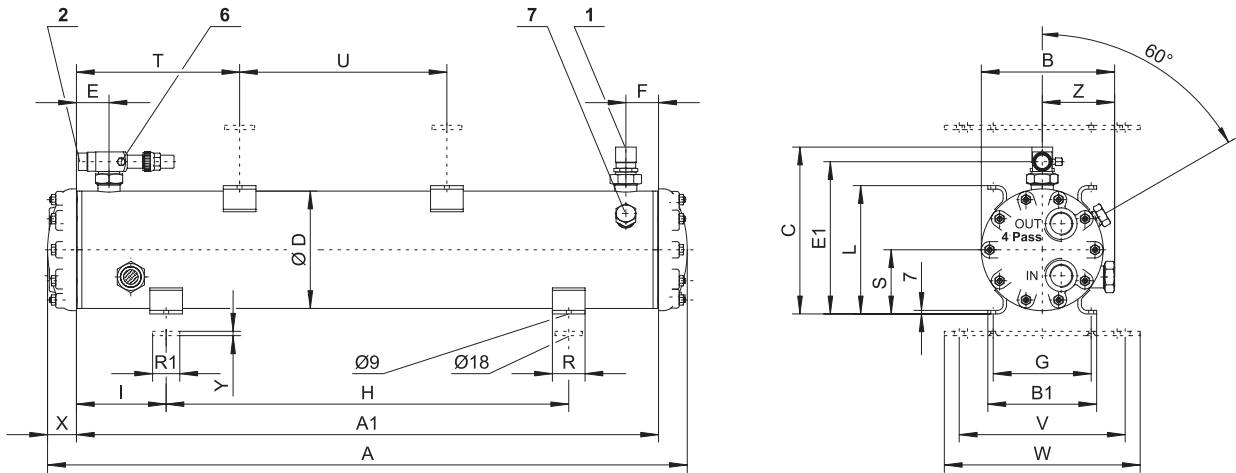

K1353T  
K1973T  
K2923T  
K3803T  
K4803T  
K6703.  
K8503.

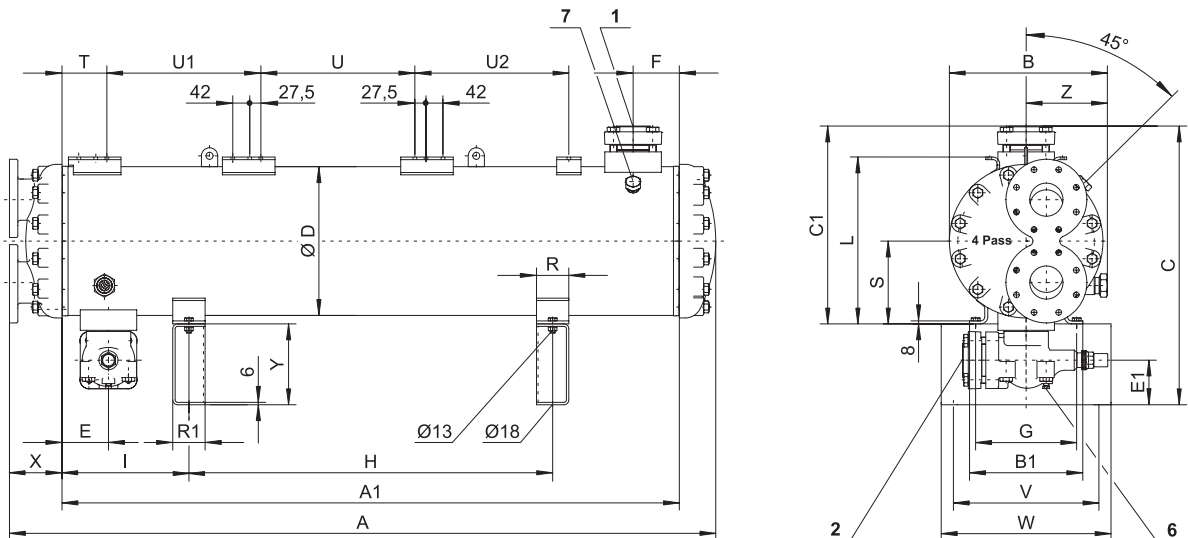

## Standard design

### Dimensions

Model	Dimensions in mm												
	-Pass	A	A1	B	B1	C	C1	ØD	E	E1	F	G	H
<b>K033N</b>	606	517	152	130	184	–	108	50	154	50	110	400	58
<b>K033H</b>	606	517	152	130	184	–	108	50	154	50	110	400	58
<b>K073H</b>	606	517	152	130	184	–	108	50	154	50	110	400	58
<b>K123H</b>	856	767	152	130	172	–	108	60	154	60	110	400	184
<b>K203H</b>	860	767	197	130	234	–	159	60	213	60	110	400	184
<b>K283H</b>	860	767	197	130	242	–	159	60	223	60	110	400	184
<b>K373H</b>	1110	1017	197	130	248	–	159	60	223	60	110	740	138
<b>K573H</b>	1176	1070	245	200	308	–	216	60	279	60	180	740	165
<b>K813H</b>	1176	1070	245	200	308	–	216	60	279	60	180	740	165
<b>K1053H</b>	1634	1528	245	200	324	–	216	70	279	70	180	900	314
<b>K1353T</b>	1634	1528	245	200	394	324	216	70	27	70	180	900	314
<b>K1973T-4(2)</b>	1661 (1694)	1527	333	280	541	401	298	102	95	102	250	900	314
<b>K2923T-4(2)</b>	1661 (1694)	1527	333	280	561	401	298	102	88	102	250	900	322
<b>K3803T-4(2)</b>	1739 (1749)	1519	391	280	684	484	368	110	112	110	250	900	310
<b>K4803T-4(2)</b>	1739 (1749)	1519	391	280	684	484	368	110	112	110	250	900	310
<b>K6703N-4(2)</b>	2037	1528	494	335	834	642	500	125	111	125	305	900	314
<b>K6703T-4(2)</b>	2037	1528	494	335	834	642	500	125	111	125	305	900	314
<b>K8503N-4(2)</b>	2037	1528	494	335	834	642	500	125	111	125	305	900	314
<b>K8503T-4(2)</b>	2037	1528	494	335	834	642	500	125	111	125	305	900	314

Model	Dimensions in mm													
	-Pass	L	R	R1	S	T	U	U1	U2	V	W	X	Y	Z
<b>K033N</b>	–	60	45	62	–	–	–	–	–	212	250	47	6	87
<b>K033H</b>	125	60	45	62	132	236	–	–	–	212	250	47	6	87
<b>K073H</b>	125	60	45	62	132	236	–	–	–	212	250	47	6	87
<b>K123H</b>	125	60	50	62	262	295	–	–	–	275	320	47	6	87
<b>K203H</b>	190	60	50	95	218	335	–	–	–	275	320	52	8	113
<b>K283H</b>	190	60	50	95	218	335	–	–	–	275	320	52	8	113
<b>K373H</b>	190	60	50	95	344	335	–	–	–	275	320	52	8	113
<b>K573H</b>	236	60	50	118	300	381	–	–	–	305	360	53	8	133
<b>K813H</b>	236	60	50	118	300	381	–	–	–	305	360	53	8	133
<b>K1053H</b>	236	130	70	118	498	381	–	–	–	305	360	53	70	133
<b>K1353T</b>	236	130	70	118	117	381	381	381	–	305	360	53	70	133
<b>K1973T-4(2)</b>	337	80	70	169	108	381	381	381	–	305	360	67 (100)	140	178
<b>K2923T-4(2)</b>	337	80	80	169	108	381	381	381	–	360	420	67 (100)	160	178
<b>K3803T-4(2)</b>	413	80	80	205	106	381	381	381	–	360	420	130 (140)	200	201
<b>K4803T-4(2)</b>	413	80	80	205	106	381	381	381	–	360	420	130 (140)	200	201
<b>K6703N-4(2)</b>	545	80	80	374	–	–	–	–	–	360	420	406	200	244
<b>K6703T-4(2)</b>	545	80	80	374	111	381	381	381	–	360	420	406	200	244
<b>K8503N-4(2)</b>	545	80	80	374	–	–	–	–	–	360	420	406	200	244
<b>K8503T-4(2)</b>	545	80	80	374	111	381	381	381	–	360	420	406	200	244

For plastic-coated coolant reversing covers, the dimensions of the seawater design apply.

All dimensions can have tolerances according to EN ISO13920-B..

For refrigerant and coolant connections see page 13.

- 1 Refrigerant inlet
- 2 Refrigerant outlet
- 6 Pressure gauge connection until K1973TB  $\frac{7}{16}$ -20 UNF from K2923TB  $\frac{1}{4}$ -18 NPTF
- 7 Connection for pressure relief valve Internal thread  $\frac{3}{8}$ -18 NPTF External thread 1  $\frac{1}{4}$ -12 UNF

Seawater resistant design

Dimensional drawings

K033NB  
K033HB  
K073HB

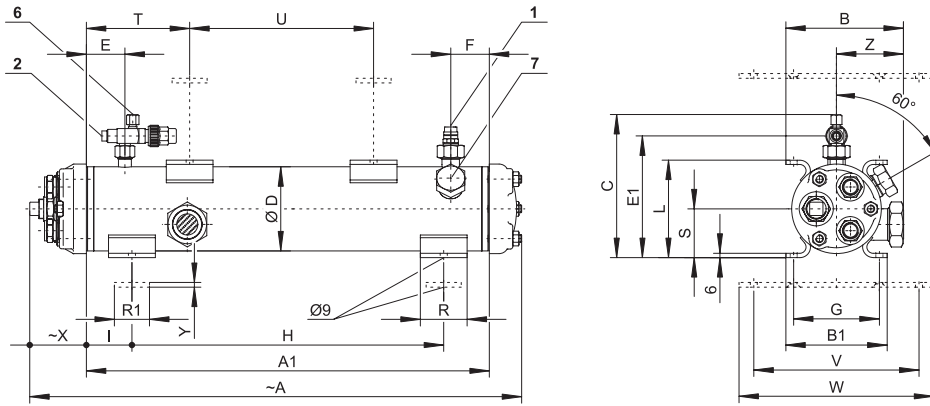

K123HB  
K203HB  
K283HB  
K373HB  
K573HB  
K813HB

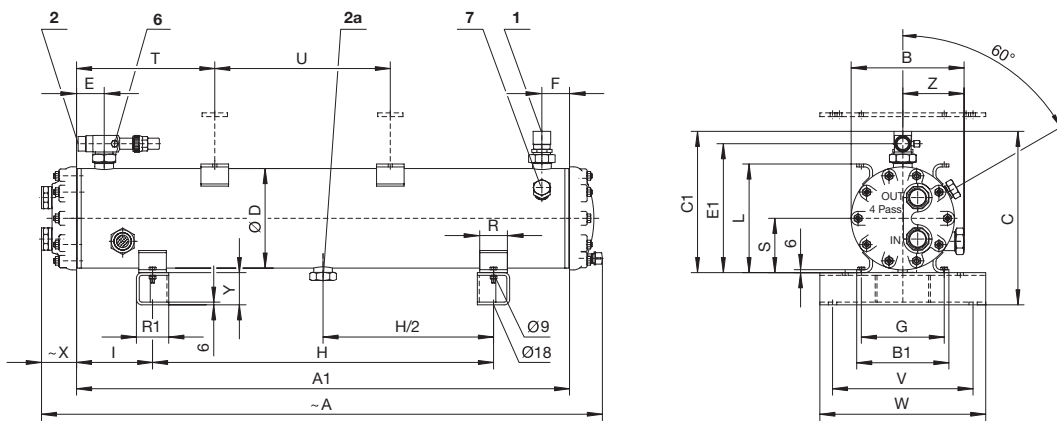

K1053HB  
K1353TB  
K1973TB  
K2923TB

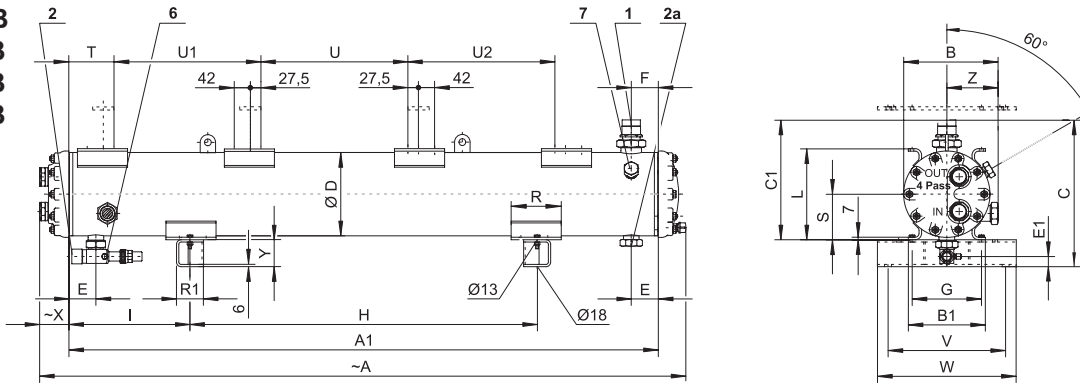

K3803TB  
K4803TB  
K6703.B  
K8503.B

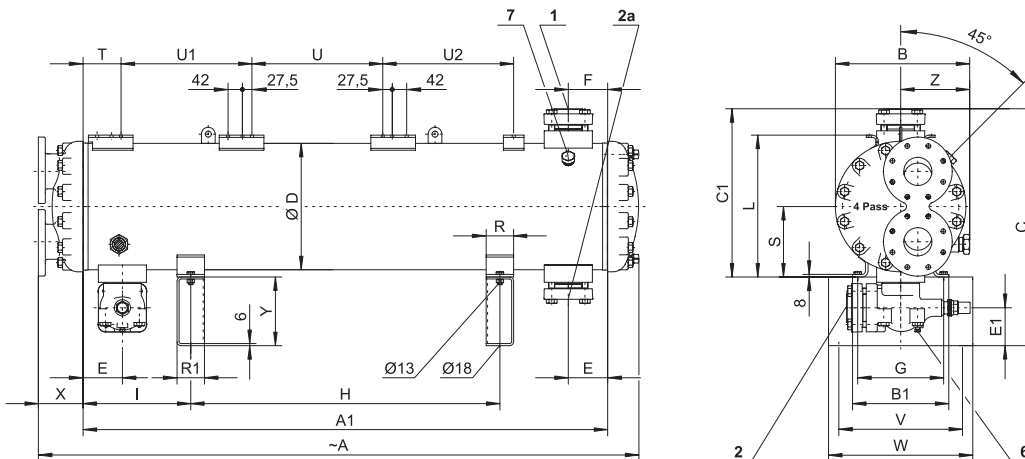

## Seawater resistant design

### Dimensions

Model	Dimensions in mm													
	-Pass	A	A1	B	B1	C	C1	ØD	E	E1	F	G	H	I
<b>K033NB</b>		626	517	152	130	184	–	108	50	156	50	110	400	58
<b>K033HB</b>		626	517	152	130	184	–	108	50	156	110	110	400	58
<b>K073HB</b>		626	517	152	130	184	–	108	50	155	50	110	400	58
<b>K123HB</b>		876	767	152	130	237	172	108	60	154	60	110	400	184
<b>K203HB</b>		882	767	197	130	299	234	159	60	213	60	110	400	184
<b>K283HB</b>		882	767	197	130	307	242	159	60	223	60	110	400	184
<b>K373HB</b>		1132	1017	197	130	313	248	159	60	223	60	110	740	138
<b>K573HB</b>		1210	1070	245	200	378	308	216	60	279	60	180	740	165
<b>K813HB</b>		1210	1070	245	200	378	308	216	60	279	60	180	740	165
<b>K1053HB</b>		1668	1528	245	200	394	324	216	70	27	70	180	900	314
<b>K1353TB</b>		1668	1528	245	200	394	324	216	70	27	70	180	900	314
<b>K1973TB-4(2)</b>		1687 (1690)	1519	333	280	541	401	298	102	95	102	250	900	314
<b>K2923TB-4(2)</b>		1687 (1690)	1519	333	280	561	401	298	102	88	102	250	900	322
<b>K3803TB-4(2)</b>		1739 (1745)	1519	391	280	686	486	368	110	114	110	250	900	310
<b>K4803TB-4(2)</b>		1739 (1745)	1519	391	280	686	486	368	110	114	110	250	900	310
<b>K6703NB-4(2)</b>		2037	1528	494	335	834	642	500	125	111	125	305	900	314
<b>K6703TB-4(2)</b>		2037	1528	494	335	834	642	500	125	111	125	305	900	314
<b>K8503NB-4(2)</b>		2037	1528	494	335	834	642	500	125	111	125	305	900	314
<b>K8503TB-4(2)</b>		2037	1528	494	335	834	642	500	125	111	125	305	900	314

Model	Dimensions in mm													
	-Pass	L	R	R1	S	T	U	U1	U2	V	W	X	Y	Z
<b>K033NB</b>		–	60	45	62,5	–	–	–	–	212	250	67	6	87
<b>K033HB</b>		125	60	45	62,5	132	236	–	–	212	250	67	6	87
<b>K073HB</b>		125	60	45	62,5	132	236	–	–	212	250	67	6	87
<b>K123HB</b>		125	60	50	62,5	262	295	–	–	275	320	67	65	87
<b>K203HB</b>		190	60	50	95	218	335	–	–	275	320	73	65	113
<b>K283HB</b>		190	60	50	95	218	335	–	–	275	320	73	65	113
<b>K373HB</b>		190	60	50	95	344	335	–	–	275	320	73	65	113
<b>K573HB</b>		236	60	70	118	300	381	–	–	305	360	76	70	133
<b>K813HB</b>		236	60	70	118	300	381	–	–	305	360	76	70	133
<b>K1053HB</b>		236	130	70	118	498	381	–	–	305	360	76	70	133
<b>K1353TB</b>		236	130	70	118	117	381	381	381	305	360	76	70	133
<b>K1973TB-4(2)</b>		337	80	70	169	108	381	381	381	305	360	100	140	178
<b>K2923TB-4(2)</b>		337	80	80	169	108	381	381	381	360	420	100	160	178
<b>K3803TB-4(2)</b>		413	80	80	205	106	381	381	381	360	420	130 (140)	200	201
<b>K4803TB-4(2)</b>		413	80	80	205	106	381	381	381	360	420	130 (140)	200	201
<b>K6703NB-4(2)</b>		545	80	80	374	–	–	–	–	360	420	406	200	244
<b>K6703TB-4(2)</b>		545	80	80	374	111	381	381	381	360	420	406	200	244
<b>K8503NB-4(2)</b>		545	80	80	374	–	–	–	–	360	420	406	200	244
<b>K8503TB-4(2)</b>		545	80	80	374	111	381	381	381	360	420	406	200	244

All dimensions can have tolerances according to EN ISO13920-B.

For refrigerant and coolant connections see page 13.

- 1 Refrigerant inlet
- 2 Refrigerant outlet
- 2a Additional refrigerant outlet
- 6 Pressure gauge connection until K1973TB  $7/16$  -20 UNF from K2923TB  $1/4$  -18 NPTF
- 7 Connection for pressure relief valve Internal thread  $3/8$  -18 NPTF External thread  $1 1/4$  -12 UNF

## Coolant reversing covers

Model	Connection end	Reversing end
4-pass or 2-pass depending on connection		
K033.(B) K073H.(B) K123H.(B)		
K203H.(B) K283H.(B) K373H.(B)		
4-pass	2-pass	Reversing end
K573H.(B)-4 K813H.(B)-4 K1053H.(B)-4 K1353T.(B)-4	K573H.(B)-2 K813H.(B)-2 K1053H.(B)-2 K1353T.(B)-2	
K1973T.(B)-4 K2923T.(B)-4	K1973T.(B)-2 K2923T.(B)-2	
K3803T.(B)-4 K4803T.(B)-4	K3803T.(B)-2 K4803T.(B)-2	
K6703.(B)-4 K8503.(B)-4	K6703.(B)-2 K8503.(B)-2	

3a Coolant inlet 4-pass  
 3b Coolant inlet 2-pass  
 4a Coolant outlet 4-pass  
 4b Coolant outlet 2-pass

5 Coolant drain  
 G<sup>1</sup>/<sub>4</sub> standard design (internal thread)  
 G<sup>1</sup>/<sub>2</sub> seawater resistant design (internal thread)  
 6 Vent plug

## Refrigerant and coolant connections

Model	Refrigerant connections				2-pass coolant connections			4-pass coolant connections				
	Bushing <sup>①</sup>		Thread/Flange		Passes	Inlet	Outlet	Passes	Inlet	Outlet		
	Inlet ø	Outlet ø <sup>②</sup>	Inlet	Outlet								
mm	Zoll	mm	Zoll									
<b>K033(B)</b>	12	1/2	10	3/8	1-14 UNS	3/4-16 UNF	2	2 x G 1/2	G 3/4	4	G 1/2	G 1/2
<b>K073H(B)</b>	12	1/2	10	3/8	1-14 UNS	3/4-16 UNF	2	2 x G 1/2	G 3/4	4	G 1/2	G 1/2
<b>K123H(B)</b>	16	5/8	12	1/2	1-14 UNS	1-14 UNS	2	2 x G 1/2	G 3/4	4	G 1/2	G 1/2
<b>K203H(B)</b>	16	5/8	16	5/8	1 1/4-12 UNF	1-14 UNS	2	2 x G 3/4	G 1	4	G 3/4	G 3/4
<b>K283H(B)</b>	22	7/8	22	7/8	1 1/4-12 UNF	1 1/4-12 UNF	2	2 x G 3/4	G 1	4	G 3/4	G 3/4
<b>K373H(B)</b>	28	1 1/8	22	7/8	1 3/4-12 UN	1 1/4-12 UNF	2	2 x G 3/4	G 1	4	G 3/4	G 3/4
<b>K573H(B)</b>	35	1 3/8	28	1 1/8	1 3/4-12 UN	1 3/4-12 UN	2	G 2	G 2	4	G 1 1/4	G 1 1/4
<b>K813H(B)</b>	35	1 3/8	28	1 1/8	1 3/4-12 UN	1 3/4-12 UN	2	G 2	G 2	4	G 1 1/4	G 1 1/4
<b>K1053H(B)</b>	42	1 5/8	35	1 3/8	2 1/4-12 UN	1 3/4-12 UN	2	G 2	G 2	4	G 1 1/4	G 1 1/4
<b>K1353T(B)</b>	42	1 5/8	35	1 3/8	2 1/4-12 UN	1 3/4-12 UN	2	G 2	G 2	4	G 1 1/4	G 1 1/4
<b>K1973T(B)</b>	54	2 1/8	42	1 5/8	DN50	2 1/4-12 UN	2	DN65 <sup>③</sup>	DN65 <sup>③</sup>	4	G 2	G 2
<b>K2923T(B)</b>	54	2 1/8	54	2 1/8	DN50	DN50	2	DN65 <sup>③</sup>	DN65 <sup>③</sup>	4	G 2	G 2
<b>K3803T(B)</b>	76	3 1/8	76	3 1/8	DN80	DN80	2	DN100 <sup>③</sup>	DN100 <sup>③</sup>	4	DN80 <sup>③</sup>	DN80 <sup>③</sup>
<b>K4803T(B)</b>	76	3 1/8	76	3 1/8	DN80	DN80	2	DN100 <sup>③</sup>	DN100 <sup>③</sup>	4	DN80 <sup>③</sup>	DN80 <sup>③</sup>
<b>K6703(B)</b>	76	3 1/8	76	3 1/8	DN100	DN100	2	DN125	DN125	4	DN100	DN100
<b>K8503(B)</b>	76	3 1/8	76	3 1/8	DN100	DN100	2	DN125	DN125	4	DN100	DN100

All threads of the coolant connections are internal threads

① For other connections see Price List

② Additional refrigerant outlet (bottom) for seawater resistant design from model K123HB – see table on page 7.

③ Welding neck flanges DIN2633, ND 10/16 or threaded flanges DIN2566, ND 10/16

## Coolant connection positions on the coolant reversing cover

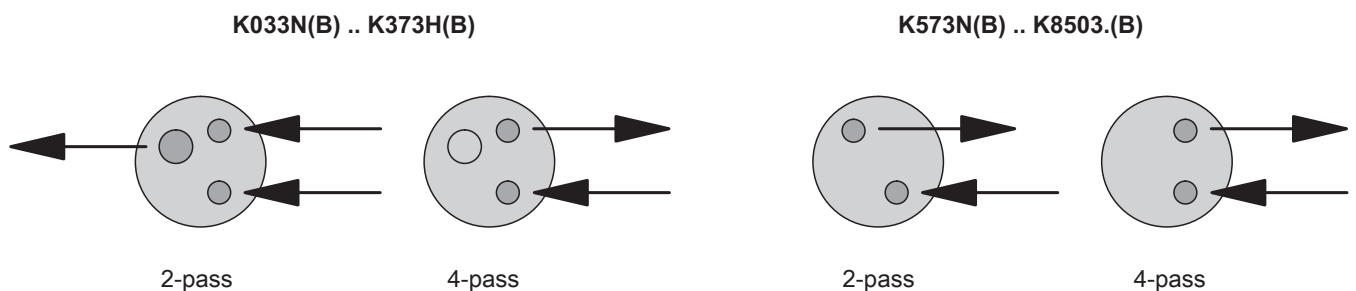

K033N(B) .. K373H(B): 4 or 2-pass, depending on connection

K573N(B) .. K8503(B): different covers for 4- or 2-pass

## Fixing rails

Model	Rails		
	Bottom	Top	For compressors
	Nr	Nr	Model
<b>K033N(B)</b>	327 301 01	–	–
<b>K073H(B)</b>	327 301 01	327 301 12	2KES-05 .. 2FES-3 2KC-05.2 .. 2FC-3.2
<b>K123H</b>	327 301 04	327 301 20 327 301 21	2KES-05 .. 2FES-3 2KC-05.2 .. 2FC-3.2 2EES-2 .. 2CES-4 2EC-2.2 .. 2CC-4.2
<b>K123HB</b>	S	327 301 20 327 301 21	2KES-05 .. 2FES-3 2KC-05.2 .. 2FC-3.2 2EES-2 .. 2CES-4 2EC-2.2 .. 2CC-4.2
<b>K203H</b>	327 301 04	327 301 21 327 301 22 327 301 24	2EES-2 .. 2CES-4 2EC-2.2 .. 2CC-4.2 4FES-3 .. 4BES-9 4FC-3.2 .. 4CC-9.2 4VES-6 .. 4NES-20 4VC(S)-6.2 .. 4NC(S)-20.2
<b>K203HB</b>	S	327 301 21 327 301 22 327 301 24	2EES-2 .. 2CES-4 2EC-2.2 .. 2CC-4.2 4FES-3 .. 4BES-9 2EC-2.2 .. 2CC-4.2 4VES-6 .. 4NES-20 4VC(S)-6.2 .. 4NC(S)-20.2
<b>K283H</b>	327 301 04	327 301 21 327 301 22 327 301 24	2EES-2 .. 2CES-4 2EC-2.2 .. 2CC-4.2 4FES-3 .. 4BES-9 4FC-3.2 .. 4CC-9.2 4VES-6 .. 4NES-20 4VC(S)-6.2 .. 4NC(S)-20.2
<b>K283HB</b>	S	327 301 21 327 301 22 327 301 24	2EES-2 .. 2CES-4 2EC-2.2 .. 2CC-4.2 4FES-3 .. 4BES-9 4FC-3.2 .. 4CC-9.2 4VES-6 .. 4NES-20 4VC(S)-6.2 .. 4NC(S)-20.2
<b>K373H</b>	327 301 04	327 301 21 327 301 22 327 301 24	2EES-2 .. 2CES-4 2EC-2.2 .. 2CC-4.2 4FES-3 .. 4BES-9 4FC-3.2 .. 4CC-9.2 4VES-6 .. 4NES-20 4VC(S)-6.2 .. 4NC(S)-20.2
<b>K373HB</b>	S	327 301 21 327 301 22 327 301 24	2EES-2 .. 2CES-4 2EC-2.2 .. 2CC-4.2 4FES-3 .. 4BES-9 4FC-3.2 .. 4CC-9.2 4VES-6 .. 4NES-20 4VC(S)-6.2 .. 4NC(S)-20.2
<b>K573H</b>	327 301 05	327 301 24 327 301 10	4VES-6 .. 4NES-20 4VC(S)-6.2 .. 4NC(S)-20.2 4JE-13 .. 6FE-50 4J-13.2 .. 6F-50.2
<b>K573HB</b>	S	327 301 24 327 301 10	4VES-6 .. 4NES-20 4VC(S)-6.2 .. 4NC(S)-20.2 4JE-13 .. 6FE-50 4J-13.2 .. 6F-50.2

Model	Rails		
	Bottom	Top	For compressors
	Nr.	Nr.	Model
<b>K813H</b>	327 301 05	327 301 24 327 301 10	4VES-6 .. 4NES-20 4VC(S)-6.2 .. 4NC(S)-20.2 4JE-13 .. 6FE-50 4J-13.2 .. 6F-50.2
<b>K813HB</b>	S	327 301 24 327 301 10	4VES-6 .. 4NES-20 4VC(S)-6.2 .. 4NC(S)-20.2 4JE-13 .. 6FE-50 4J-13.2 .. 6F-50.2
<b>K1053H</b>	327 301 06	327 301 24 327 301 10	4VES-6 .. 4NES-20 4VC(S)-6.2 .. 4NC(S)-20.2 4JE-13 .. 6FE-50 4J-13.2 .. 6F-50.2
<b>K1053HB</b>	S	327 301 24 327 301 10	4VES-6 .. 4NES-20 4VC(S)-6.2 .. 4NC(S)-20.2 4JE-13 .. 6FE-50 4J-13.2 .. 6F-50.2
<b>K1353T(B)</b>	S	327 301 24 327 301 10 326 057 01	4VES-6 .. 4NES-20 4VC(S)-6.2 .. 4NC(S)-20.2 4JE-13 .. 6FE-50 44JE-26 .. 66FE-100 44J-26.2 .. 66F-100.2
<b>K1973T(B)</b>	S	327 301 24 327 301 10 326 057 01	4VES-6 .. 4NES-20 4VC(S)-6.2 .. 4NC(S)-20.2 4JE-13 .. 6FE-50 44JE-26 .. 66FE-100 44J-26.2 .. 66F-100.2
<b>K2923T(B)</b>	S	327 301 24 327 301 10 326 057 01	4VES-6 .. 4NES-20 4VC(S)-6.2 .. 4NC(S)-20.2 4JE-13 .. 6FE-50 44JE-26 .. 66FE-100 44J-26.2 .. 66F-100.2
<b>K3803T(B)</b>	S	327 301 24 327 301 10 326 057 01	4VES-6 .. 4NES-20 4VC(S)-6.2 .. 4NC(S)-20.2 4JE-13 .. 6FE-50 44JE-26 .. 66FE-100 44J-26.2 .. 66F-100.2
<b>K4803T(B)</b>	S	327 301 24 327 301 10 326 057 01	4VES-6 .. 4NES-20 4VC(S)-6.2 .. 4NC(S)-20.2 4JE-13 .. 6FE-50 44JE-26 .. 66FE-100 44J-26.2 .. 66F-100.2
<b>K6703N(B)</b>	S	–	–
<b>K6703T(B)</b>	S	327 301 24 327 301 10 326 057 01	4VES-6 .. 4NES-20 4VC(S)-6.2 .. 4NC(S)-20.2 4JE-13 .. 6FE-50 44JE-26 .. 66FE-100 44J-26.2 .. 66F-100.2
<b>K8503N(B)</b>	S	–	–
<b>K8503T(B)</b>	S	327 301 24 327 301 10 326 057 01	4VES-6 .. 4NES-20 4VC(S)-6.2 .. 4NC(S)-20.2 4JE-13 .. 6FE-50 44JE-26 .. 66FE-100 44J-26.2 .. 66F-100.2

S = Standard

## Fixing plates

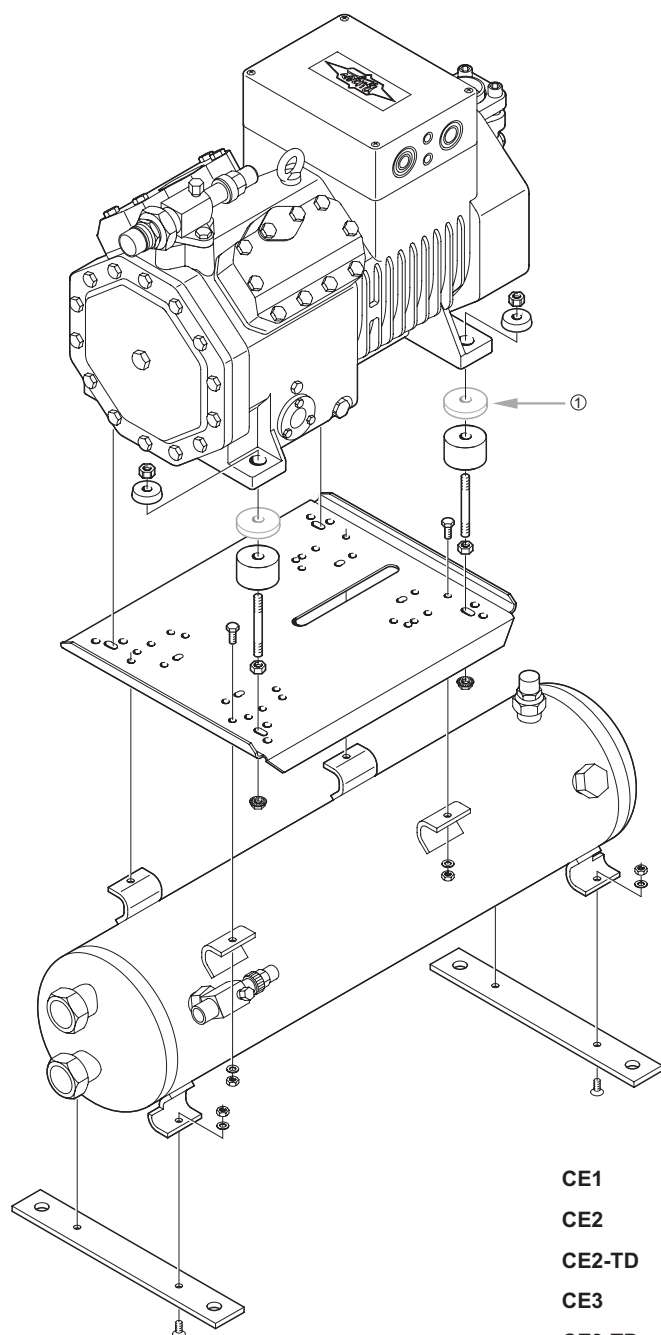

320 366 01

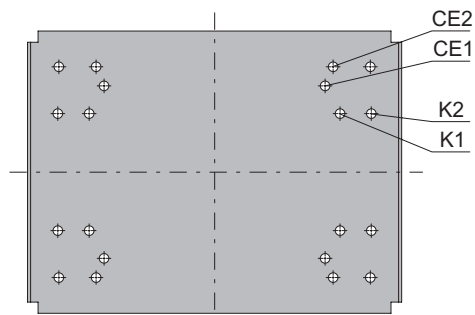

320 366 02

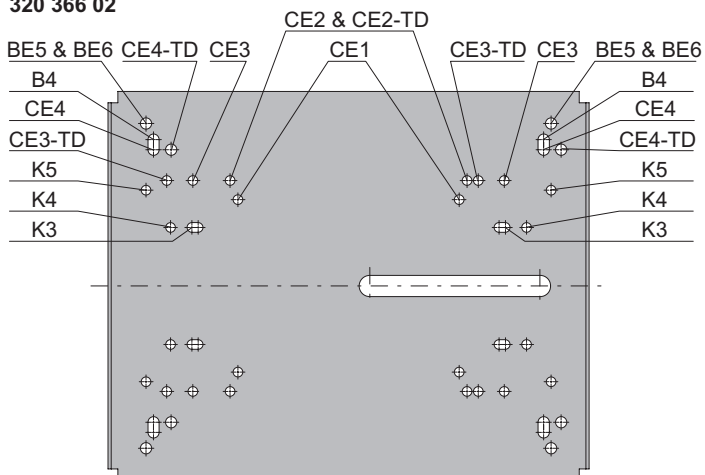

- K1** K033H(B), K073H(B)
- K2** K123H(B)
- K3** K123H(B)
- K4** K203H(B), K283H(B), K373H(B)
- K5** K573H(B), K813H(B), K1053H(B),  
K1353T(B), K1973T(B), K2923T(B)

- CE1** 2KES-05Y .. 2FES-3(Y) // 2KC-05.2(Y) .. 2FC-3.2(Y)
- CE2** 2EES-2(Y) .. 2CES-2(Y) // 2EC-2.2(Y) .. 2CC-4.2(Y)
- CE2-TD** 22EES-4(Y) .. 22CES-8(Y) // 22EC-4.2(Y) .. 22CC-8.2(Y)
- CE3** 4FES-3(Y) .. 4BES-9(Y) // 4FC-3.2(Y) .. 4CC-9.2(Y)
- CE3-TD** 44FES-6(Y) .. 44BES-18(Y) // 44FC-6.2(Y) .. 44CC-18.2(Y)
- CE4** 4VES-6(Y) .. 4NES-20(Y) // 4VC(S)-6.2(Y) .. 4NC(S)-20.2(Y)
- CE4-TD** 44VES-12Y.. 44NES-40(Y) // 44VC(S)-12.2(Y) .. 44NC(S)-40.2(Y)
- B4** 4Z-5.2(Y) .. 4N-20.2(Y)
- BE5** 4JE-13Y .. 4FE-35(Y) // 4J-13.2(Y) .. 4G-30.2(Y)
- BE5-TD** 44JE-26Y .. 44FE-70(Y) // 44J-26.2(Y) .. 44G-60.2(Y)
- BE6** 6JE-22Y .. 6FE-50(Y) // 6J-22.2(Y) .. 6F-50.2(Y)
- BE6-TD** 66JE-44Y .. 66FE-100(Y) // 66J-44.2(Y) .. 66F-100.2(Y)

⊙ Only with CE1/C1

For possible compressor/condenser combinations see page 14.



**BITZER Kühlmaschinenbau GmbH**  
Eschenbrünnelestraße 15 // 71065 Sindelfingen // Germany  
Tel +49 [0]70 31 932-0 // Fax +49 [0]70 31 932-147  
bitzer@bitzer.de // www.bitzer.de

Subject to change // 80192301 // 12.2025